

Kinco

Servo Motor Servo Driver

Kinco®



Servo Motor Servo Driver

Kinco®

Kinco Automation(Shanghai) Ltd.

Add: Bldg.1, No.1387 Zhangdong Rd.,
Zhangjiang Hi-Tech Park, Shanghai, China 201203
Tel:86-21-68798588 Fax:86-21-68797688
Email: sales@kinco.cn <http://www.kinco.cn>

(All trademarks and logos in this brochure are property of and registered by their respective owners.)

KO01EN08-1104

Kinco Automation(Shanghai) Ltd.

Kinco ED Series Intelligent Servo System

Kinco ED series servo is integrated with such function as driver, control, bus and I/O, supports three modes of speed, position and torque. ED series driver includes internal PLC function, the driver can implement a maximum of 256 motion curve, including such important motion curve parameters as acceleration, deceleration, maximum speed and target position. ED series servo is specially suitable for master-slave system, its electronic gear rate can be adjustable, and its following speed and precision are much stronger than control by PLC because ED servo no need scanning cycle. ED series servo supply multiple communication modes including Rs232, Rs485, CANOpen, Profibus DP. With open protocol provided by us, PLC, PC, single-chip microcomputer or other controllers can communicate with ED series servo. ED series servo driver contain 8 digital input and 2 digital output, can be used to call internal sequences.

ED series servo can directly communicate with kinco HMI, implementing modifying control parameters and displaying real-time data. This solution doesn't need PLC, PC or single-chip microcomputer, which is necessary in a conventional solution, and thus saving the cost for the user.



3-Phase Servo System

Naming Rules

Naming Rules for 3-phase Servo Drivers

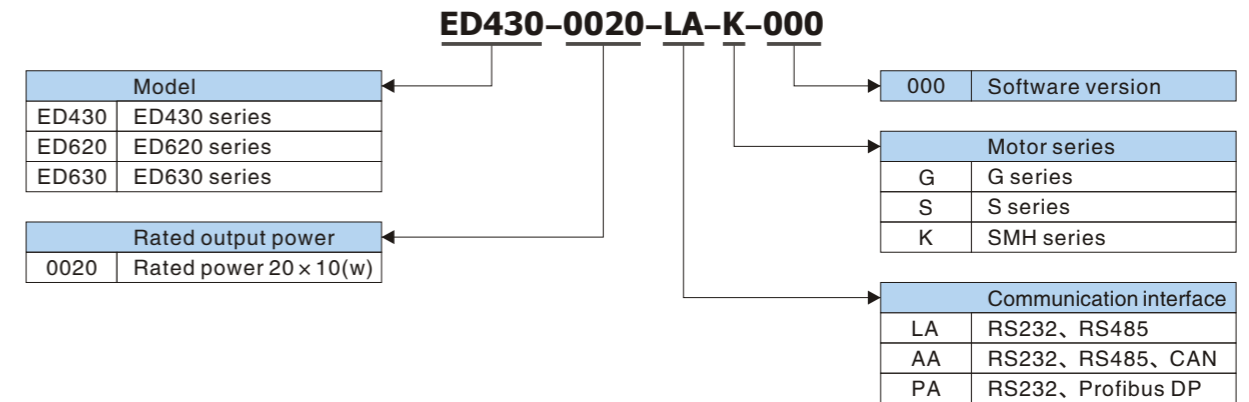

Small-inertia
3-phase Servo Motor

•60S •80S



Medium-inertia
3-phase Servo Motor

•110D •126D
•130D •155D



•ED430 3-phase Driver



•ED620/ED630
3-phase Driver



Naming Rules

Naming Rules for 3-phase Servo Motor of S and G Series

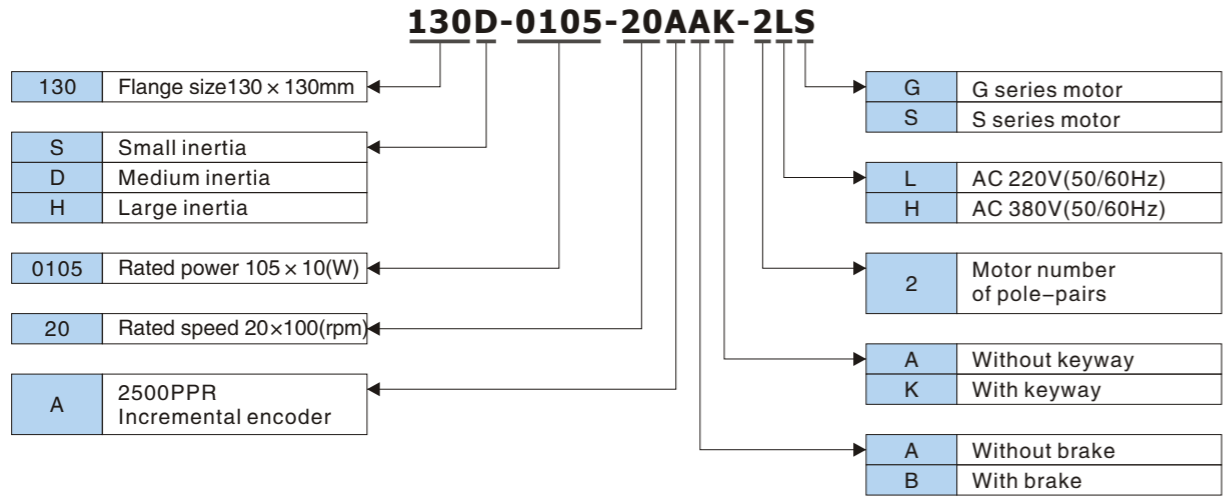

Naming Rules for Motor Cable and Encoder Cable of S and G Series Servo

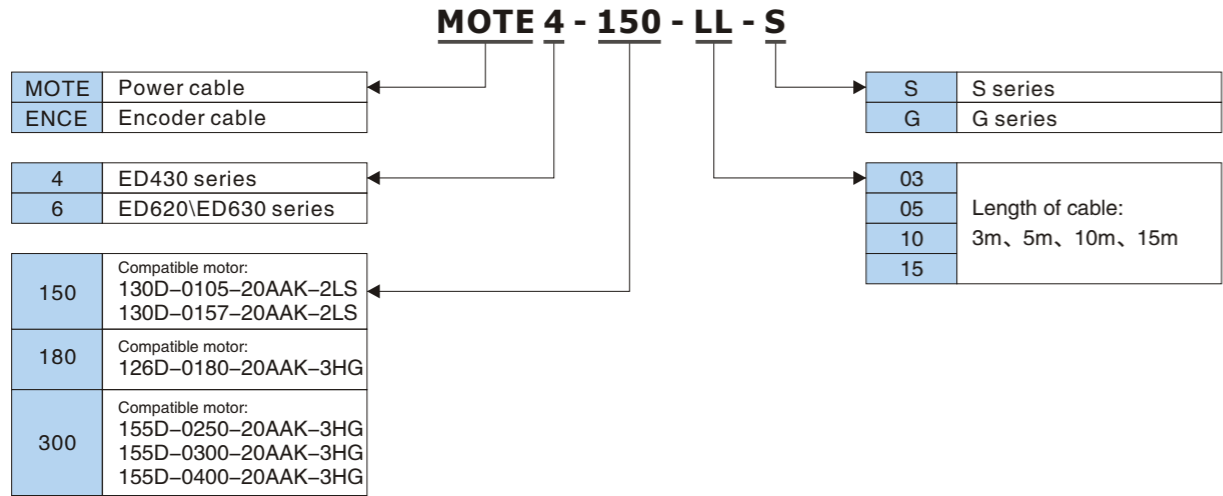

Naming Rules

Naming Rules for SMH Series Servo Motor

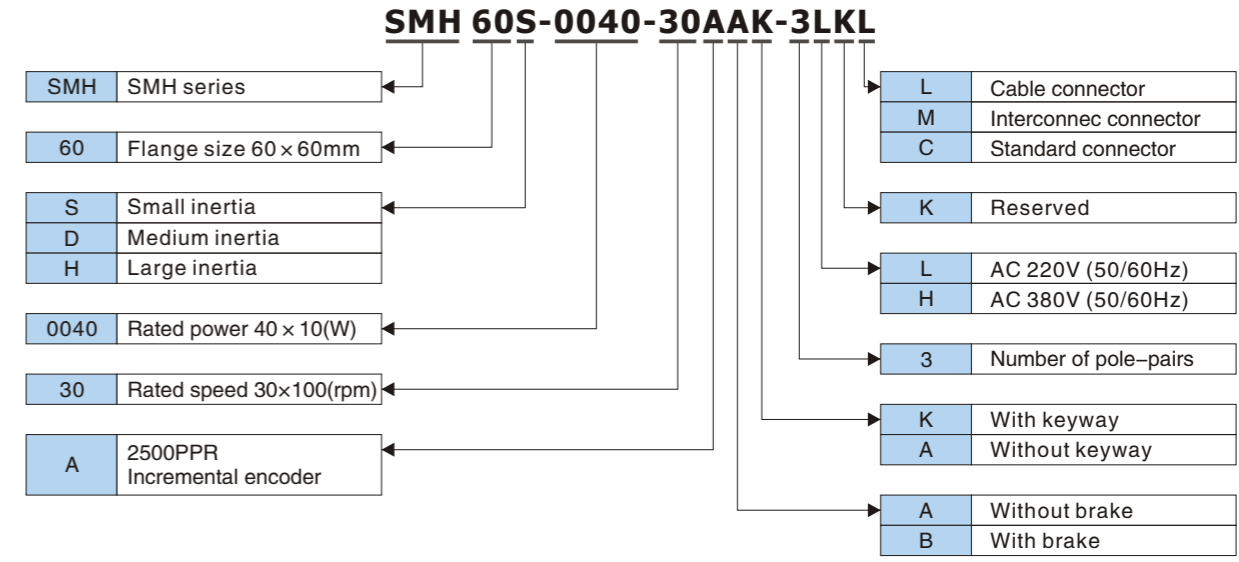

Naming Rules for Motor Cable and Encoder Cable of SMH Series Servo

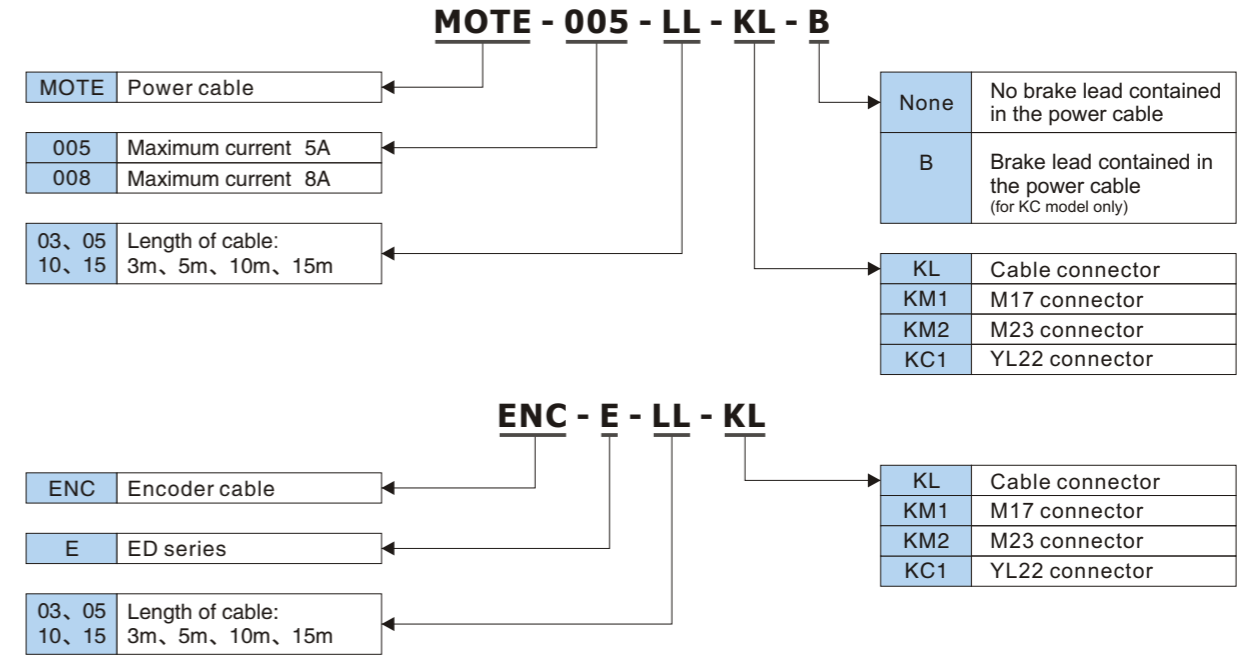

Dimensions/Torque Curve/Technical Specifications of SMH60 Servo Motors

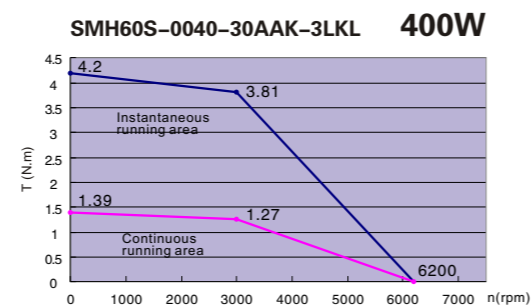
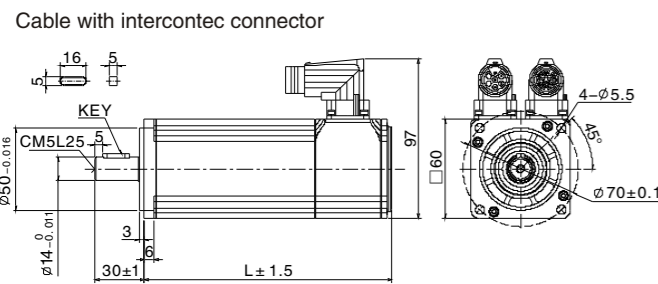
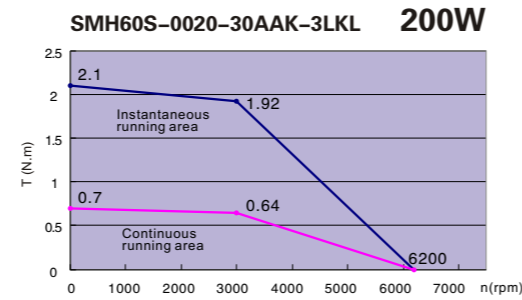
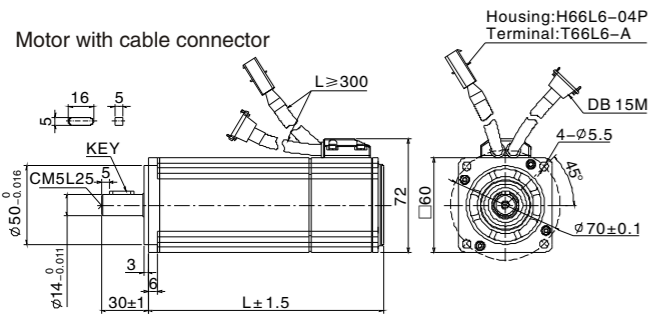

Motor series	Small inertia, flange size 60mm		
Model	SMH60S-0020-30AAK-3LKL	SMH60S-0040-30AAK-3LKL	
Compatible driver	ED430-0020-□A-K-000	ED430-0040-□A-K-000	
Power supply VAC	220V	220V	
Rated output power	200W	400W	
Rated torque (N · m)	0.64	1.27	
Maximum torque(N · m)	1.92	3.82	
Rated speed(rpm)	3000	3000	
Maximum speed(rpm)	6200	6200	
Motor inertia(Kg · cm ²)	0.375	0.51	
Transformer capacity(KVA)	0.5	1	
Encoder	2500p/r (Resolution: 10000)	2500p/r (Resolution: 10000)	
Rated current(A)	1.63	3.08	
Maximum current(A)	4.89	9.24	
Torque constant(Nm/A)	0.48	0.48	
Resistance line-line(Ω)	8.02	3.52	
Inductance line-line(mH)	16.3	7.8	
Electrical time constant(ms)	2.03	2.22	
Mechanical time constant(ms)	2.26	1.35	
Maximum radial force F(N)	180	180	
Maximum axial force F(N)	90	90	
Pole pair number	3	3	
Insulation class	F	F	
Protection class	IP65 for body, shaft sealing for IP54	IP65 for body, shaft sealing for IP54	
Environment condition for operation	Temperature	-20°C ~ 40°C (non-freezing)	
	Humidity	Below 90%RH (non-condensing)	
	Ambient environment	Away from active gas, combustible gas, oil drops and dust	
	Altitude	Maximum altitude 4000m. Rated power at 1000m.Above 1000m, decreasing 1.5% power per 100m rise	
Motor weight (Kg)	1.3	1.8	
Motor length (mm)	120	150	

Notes: □= L: With RS232,RS485
□= A: With RS232,RS485,CANOpen
□= P: With RS232,Profibus-DP

Dimensions/Torque Curve/Technical Specifications of SMH80 Servo Motors

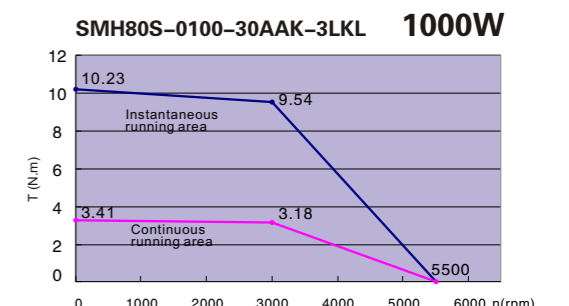
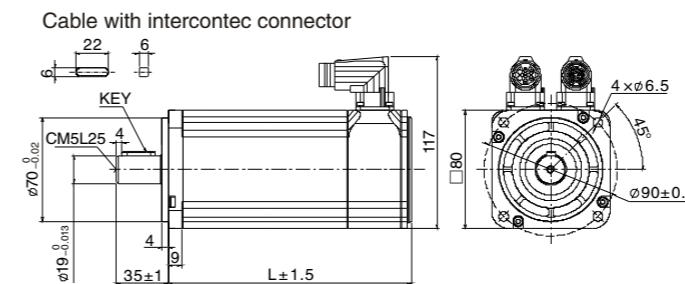
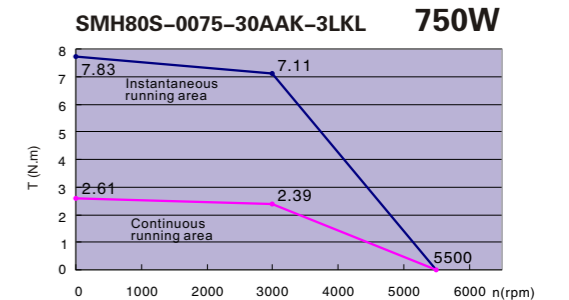
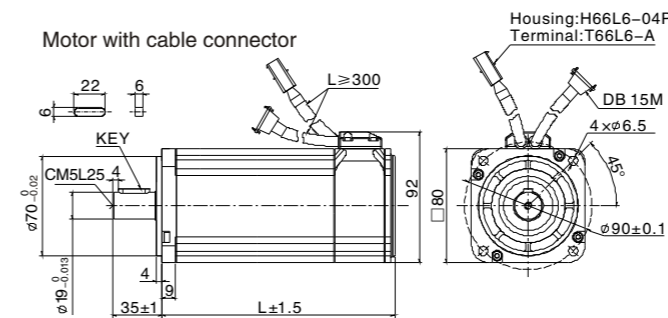

Motor series	Small inertia, flange size 80mm		
Model	SMH80S-0075-30AAK-3LKL	SMH80S-0100-30AAK-3LKL	
Compatible driver	ED430-0075-□A-K-000	ED430-0100-□A-K-000	
Power supply VAC	220V	220V	
Rated output power	750W	1KW	
Rated torque (N · m)	2.39	3.18	
Maximum torque(N · m)	7.17	9.48	
Rated speed(rpm)	3000	3000	
Maximum speed(rpm)	5500	5500	
Motor inertia(Kg · cm ²)	1.36	1.9	
Transformer capacity(KVA)	1.3	1.8	
Encoder	2500p/r (Resolution: 10000)	2500p/r (Resolution: 10000)	
Rated current(A)	4.0	6.3	
Maximum current(A)	12	18.9	
Torque constant(Nm/A)	0.662	0.562	
Resistance line-line(Ω)	1.4	0.86	
Inductance line-line(mH)	7.5	4.5	
Electrical time constant(ms)	5.35	5.23	
Mechanical time constant(ms)	0.75	0.89	
Maximum radial force F(N)	335	335	
Maximum axial force F(N)	167.5	167.5	
Pole pair number	3	3	
Insulation class	F	F	
Protection class	IP65 for body, shaft sealing for IP54	IP65 for body, shaft sealing for IP54	
Environment condition for operation	Temperature	-20°C ~ 40°C (non-freezing)	
	Humidity	Below 90%RH (non-condensing)	
	Ambient environment	Away from active gas, combustible gas, oil drops and dust	
	Altitude	Maximum altitude 4000m. Rated power at 1000m.Above 1000m, decreasing 1.5% power per 100m rise	
Motor weight (Kg)	3.3	3.9	
Motor length (mm)	147	167	

Notes: □= L: With RS232,RS485
□= A: With RS232,RS485,CANOpen
□= P: With RS232,Profibus-DP

Dimensions/Torque Curve of SMH110 Servo Motors

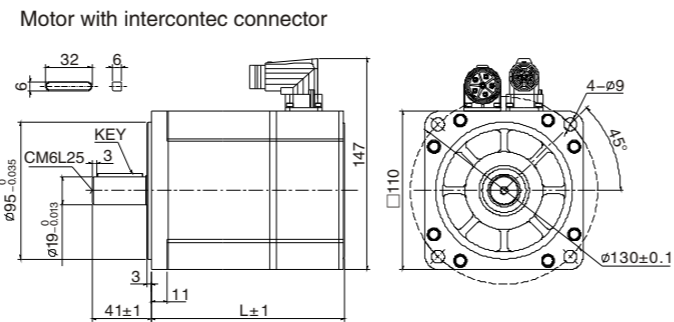
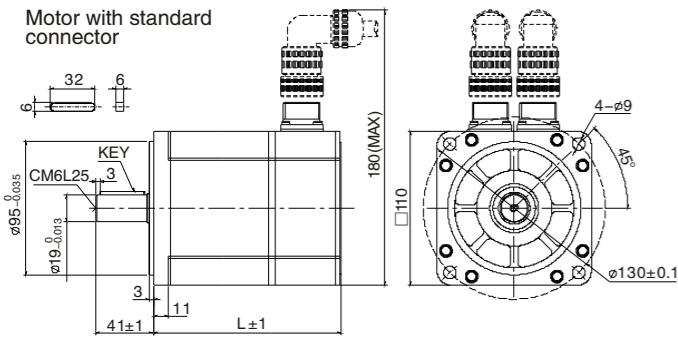

SMH110D-0105-20AAK-4LKC 1.05KW

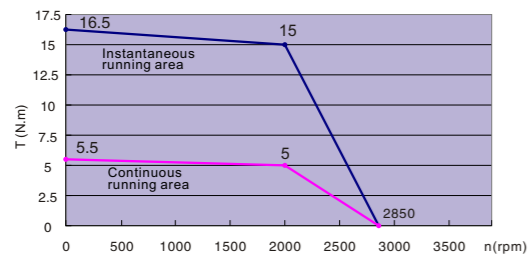

SMH110D-0126-20AAK-4LKC 1.26KW

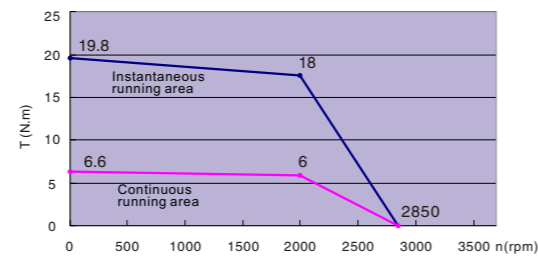

SMH110D-0125-30AAK-4LKC 1.25KW

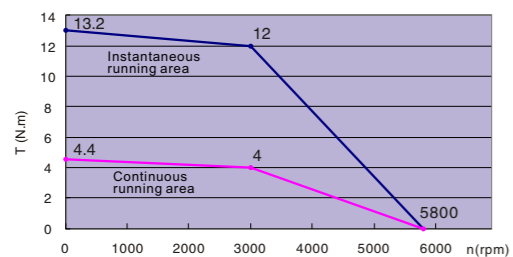

SMH110D-0126-30AAK-4HKC 1.26KW

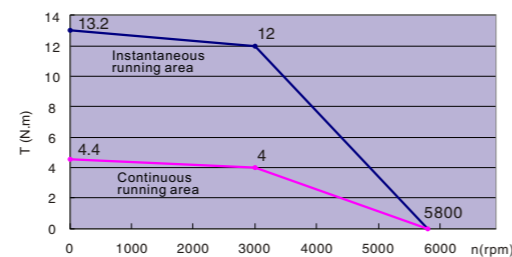

SMH110D-0157-30AAK-4HKC 1.57KW

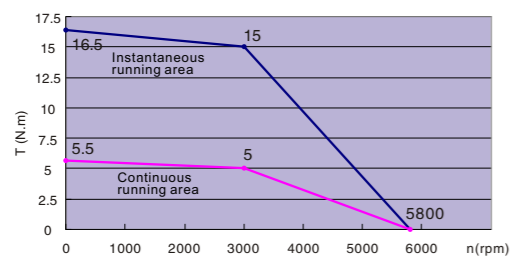

SMH110D-0188-30AAK-4HKC 1.88KW

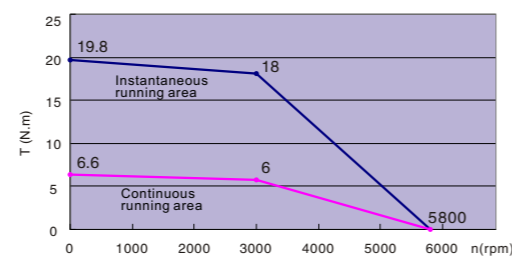

Technical Specifications of SMH110 Servo Motors

Motor series	Medium inertia, flange size 110mm					
Model	SMH110D-0105-20AAK-4LKC	SMH110D-0126-20AAK-4LKC	SMH110D-0125-30AAK-4LKC	SMH110D-0126-30AAK-4HKC	SMH110D-0157-30AAK-4HKC	SMH110D-0188-30AAK-4HKC
Compatible driver	ED430-0105 -□A-K-000	ED430-0126 -□A-K-000	ED430-0125 -□A-K-000	ED620-0126 -□A-K-000	ED620-0157 -□A-K-000	ED620-0188 -□A-K-000
Power supply VAC	220V	3-phase 220V	3-phase 220V	3-phase 380V	3-phase 380V	3-phase 380V
Rated output power	1.05KW	1.26W	1.25W	1.26W	1.57KW	1.88W
Rated torque (N · m)	5	6	4	4	5	6
Maximum torque(N · m)	15	18	12	12	15	18
Rated speed(rpm)	2000	2000	3000	3000	3000	3000
Maximum speed(rpm)	2850	2850	5800	5800	5800	5800
Motor inertia(Kg · cm ²)	7.2	8.5	5.8	5.8	7.2	8.5
Transformer capacity(KVA)	1.8	2.1	2.1	2.1	2.4	3.2
Encoder	2500p/r (Resolution: 10000)					
Rated current(A)	5.4	6.15	6.5	4.3	5.4	6.15
Maximum current(A)	16.2	18.45	18.6	12.9	16.2	18.45
Torque constant(Nm/A)	0.992	1.058	0.744	1.058	0.992	1.058
Resistance line-line(Ω)	1.37	1.258	0.8	1.83	1.37	1.258
Inductance line-line(mH)	10.5	9.62	6.4	13.5	10.5	9.62
Electrical time constant(ms)	7.66	7.64	7.9	7.37	7.66	7.64
Mechanical time constant(ms)	1.85	1.65	1.4	1.63	1.85	1.65
Maximum radial force F(N)	630	630	630	630	630	630
Maximum axial force F(N)	315	315	315	315	315	315
Pole pair number	4	4	4	4	4	4
Insulation class	F					
Protection class	IP65 for body, shaft sealing for IP54					
Environment condition for operation	Temperature	-20℃ ~ 40℃ (non-freezing)				
	Humidity	Below 90%RH (non-condensing)				
	Ambient environment	Away from active gas, combustible gas, oil drops and dust				
	Altitude	Maximum altitude 4000m. Rated power at 1000m. Above 1000m, decreasing 1.5% power per 100m rise				
Motor weight (Kg)	7.2	8.2	6.2	6.2	7.2	8.2
Motor length (mm)	185	202	168	168	185	202

Notes: □= L: With RS232,RS485
 □= A: With RS232,RS485,CANOpen
 □= P: With RS232,Profibus-DP

Dimensions/Torque Curve of 126, 130, 155 Servo Motors

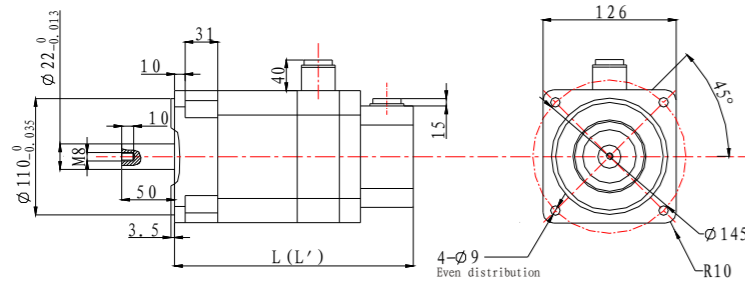

Model	L	L' (with brake)
126D-0180-20AAK-3HG	248	263

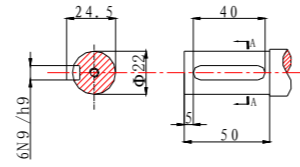

Model	L	L' (with brake)
130D-0105-20AAK-2LS	169	229
130D-0157-20AAK-2LS	189	249

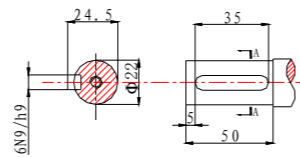

Model	L	L' (with brake)
155D-0250-20AAK-3HG	260	
155D-0300-20AAK-3HG	285	
155D-0400-20AAK-3HG	310	

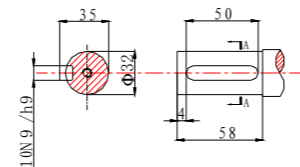

Technical Specifications of 126, 130, 155 Servo Motors

Motor series	Medium inertia, flange size 126mm, 130mm, 155mm					
Model	130D-0105-20AAK-2LS	130D-0157-20AAK-2LS	126D-0180-30AAK-3HG	155D-0250-30AAK-3HG	155D-0300-30AAK-3HG	155D-0400-30AAK-3HG
Compatible driver	ED430-0105 -□A-S-000	ED430-0157 -□A-S-000	ED620-0180 -□A-G-000	ED630-0250 -□A-G-000	ED630-0300 -□A-G-000	ED630-0400 -□A-G-000
Power supply VAC	220V	3-phase 220V	3-phase 380V	3-phase 380V	3-phase 380V	3-phase 380V
Rated output power	1.05KW	1.57KW	1.80KW	2.50KW	3.00KW	4.00KW
Rated torque (N·m)	5	7.5	8.8	12	14.3	19
Maximum torque(N·m)	15	22.5	26.4	36	35.75	47
Rated speed(rpm)	2000	2000	2000	2000	2000	2000
Maximum speed(rpm)	3000	3000	3000	3000	3000	3000
Motor inertia(Kg·cm ²)	7.4	13.1	17	26.7	35.7	47.5
Transformer capacity(KVA)	1.8	2.4	3.2	3.8	4.5	5.4
Encoder	2500p/r (Resolution: 10000)					
Rated current(A)	4.2	6	5.6	6.8	10	13
Maximum current(A)	13.4	18	16.8	20.4	30	39
Torque constant(Nm/A)	1.19	1.25	1.96	1.76	1.43	1.46
Resistance line-line(Ω)	1.22	0.98	0.87	0.95	0.91	0.88
Inductance line-line(mH)	6.08	6.94	10.3	10.8	11.2	11.5
Electrical time constant(ms)	4.98	7.08	11.8	11.4	12.3	13.1
Mechanical time constant(ms)	5.73	7.25	1.45	1.43	1.57	1.68
Maximum radial force F(N)	1508	1508	680	1320	1320	1320
Maximum axial force F(N)	960	960	350	650	650	650
Pole pair number	2	2	3	3	3	3
Insulation class	F					
Protection class	IP65 for body, shaft sealing for IP54					
Environment condition for operation	Temperature	-20°C ~ 40°C (non-freezing)				
	Humidity	Below 90%RH (non-condensing)				
	Ambient environment	Away from active gas, combustible gas, oil drops and dust				
	Altitude	Maximum altitude 4000m. Rated power at 1000m. Above 1000m, decreasing 1.5% power per 100m rise				
Motor weight (Kg)	8	9.5	15.3	17.9	20.9	22.5

Notes: □= L: With RS232,RS485
 □= A: With RS232,RS485,CANOpen
 □= P: With RS232,Profibus-DP

130D-0105-20AAK-2LS 1.05KW

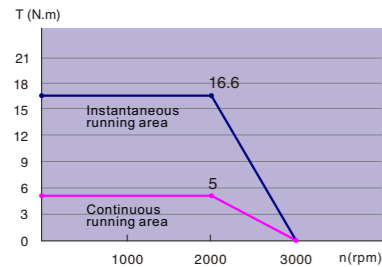

130D-0157-20AAK-2LS 1.57KW

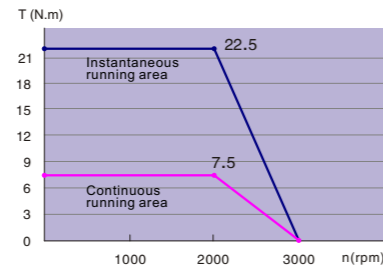

126D-0180-20AAK-3HG 1.8KW

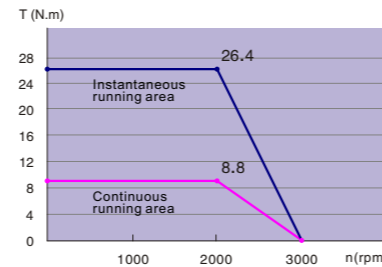

155D-0250-20AAK-3HG 2.5KW

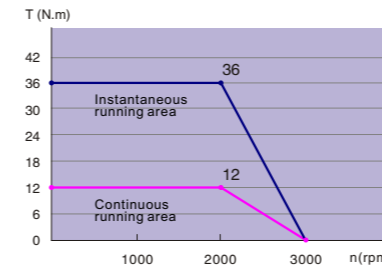

155D-0300-20AAK-3HG 3KW

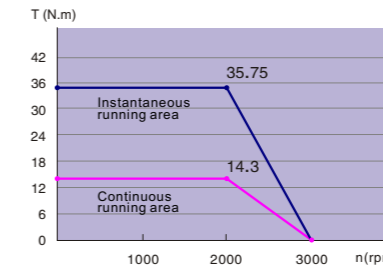

155D-0400-20AAK-3HG 4KW

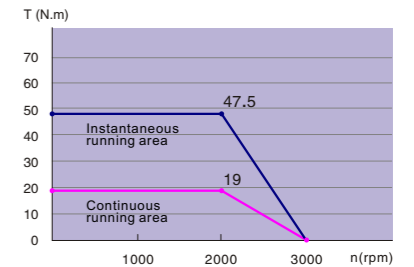

ED Servo Drivers and Motors Selection Table

Category	Power	Driver	Motor	Description	Power cable	Encoder cable	Fittings model for power cable	Fittings model for encoder cable
Small Inertia 220V	200W	ED430-0020-LA-K-000	SMH60S-0020-30AAK-3LKL	3000rpm, 0.64Nm Cable connector, with keyway	MOTE-005 -□□-KL	ENCE- □□-KL	MOT-KL	ENCE-KL
		ED430-0020-AA-K-000						
		ED430-0040-PA-K-000						
	400W	ED430-0040-LA-K-000	SMH60S-0040-30AAK-3LKL	3000rpm, 1.27Nm Cable connector, with keyway				
		ED430-0040-AA-K-000						
		ED430-0040-PA-K-000						
	750W	ED430-0075-LA-K-000	SMH80S-0075-30AAK-3LKL	3000rpm, 2.39Nm Cable connector, with keyway				
		ED430-0075-AA-K-000						
		ED430-0075-PA-K-000						
	1000W	ED430-0100-LA-K-000	SMH80S-0100-30AAK-3LKL	3000rpm, 3.18Nm Cable connector, with keyway				
		ED430-0100-AA-K-000						
		ED430-0100-PA-K-000						
Medium Inertia 220V	1.05KW	ED430-0105-LA-K-000	SMH110D-0105-20AAK-4LKC	2000rpm, 5Nm Standard connector, with keyway	MOTE-008 -□□-KC1	ENCE- □□-KC1	MOT-KC1	ENCE-KC1
		ED430-0105-AA-K-000						
		ED430-0105-PA-K-000						
	1.26KW	ED430-0126-LA-K-000	SMH110D-0126-20AAK-4LKC	2000rpm, 6Nm Standard connector, with keyway				
		ED430-0126-AA-K-000						
		ED430-0126-PA-K-000						
	1.25KW	ED430-0125-LA-K-000	SMH110D-0125-30AAK-4LKC	3000rpm, 4Nm Standard connector, with keyway				
		ED430-0125-AA-K-000						
		ED430-0125-PA-K-000						
	1.05KW	ED430-0105-LA-S-000	130D-0105-20AAK-2LS	2000rpm, 5Nm Standard connector, with keyway				
		ED430-0105-AA-S-000						
		ED430-0105-AA-S-000						
1.57KW	ED430-0157-LA-S-000	130D-0157-20AAK-2LS	2000rpm, 7.5Nm Standard connector, with keyway					
	ED430-0157-AA-S-000							
	ED430-0157-AA-S-000							
Medium Inertia 380V	1.26KW	ED620-0126-LA-K-000	SMH110D-0126-30AAK-4HKC	3000rpm, 4Nm Standard connector, with keyway	MOTE-008 -□□-KC1	ENCE- □□-KC1	MOT-KC1	ENCE-KC1
		ED620-0126-AA-K-000						
		ED620-0126-PA-K-000						
	1.57KW	ED620-0157-LA-K-000	SMH110D-0157-30AAK-4HKC	3000rpm, 5Nm Standard connector, with keyway				
		ED620-0157-AA-K-000						
		ED620-0157-PA-K-000						
1.88KW	ED620-0188-LA-K-000	SMH110D-0188-30AAK-4HKC	3000rpm, 6Nm Standard connector, with keyway					
	ED620-0188-AA-K-000							
	ED620-0188-PA-K-000							
Medium Inertia 380V	1.80KW	ED620-0180-LA-G-000	126D-0180-20AAK-3HG	2000rpm, 8.8Nm Standard connector, with keyway	MOTE6-180 -□□-G	ENCE6-180 -□□-G	MOTE6-G1	ENCE6-G1
		ED620-0180-AA-G-000						
		ED620-0180-PA-G-000						
	2.50KW	ED630-0250-LA-G-000	155D-0250-20AAK-3HG	2000rpm, 12Nm Standard connector, with keyway				
		ED630-0250-AA-G-000						
		ED630-0250-PA-G-000						
3.0KW	ED630-0300-LA-G-000	155D-0300-20AAK-3HG	2000rpm, 14.3Nm Standard connector, with keyway					
	ED630-0300-AA-G-000							
	ED630-0300-PA-G-000							
4.0KW	ED630-0400-LA-G-000	155D-0400-20AAK-3HG	2000rpm, 19.3Nm Standard connector, with keyway					
	ED630-0400-AA-G-000							
	ED630-0400-PA-G-000							

Example: 1.If you need 4KW servo driver with RS232/RS485 communication ports and motor with keyway, and need to order cables of length of 10m. So the configuration should be as following:

Driver model: ED630-0400-LA-G-000
Motor model: 155D-0400-20AAK-3HG
Power cable model: MOTE6-300-10-G
Encoder cable model: ENCE6-300-10-G

2.If you need 4KW servo driver with RS232/RS485 communication ports and motor with keyway, but want to make cables by yourself instead of ordering cables. So the configuration should be as following:

Driver model: ED630-0400-LA-G-000
Motor model: 155D-0400-20AAK-3HG
Fittings model for power cable: MOTE6-G2
Fittings model for encoder cable: ENCE6-G2

Notes: □□=03 Length of cable is 3m
□□=05 Length of cable is 5m
□□=10 Length of cable is 10m
□□=15 Length of cable is 15m

Wiring Diagram for The Power Cable

MOTE-005-LL-KL
Wire spec. UL303284C x 18AWG (41/0.16T) black

Color	Signal	4PIN plug
Yellow	U	PIN1
Red	V	PIN2
Black	W	PIN3
Yellow-green	PE	PIN4

MOTE-008-LL-KL
Wire spec. cable 4C x 1.5mm²

Color	Signal	4PIN plug
1	U	PIN1
2	V	PIN2
3	W	PIN3
Yellow-green	PE	PIN4

MOTE-008-LL-KC1
Wire spec. cable 4C x 1.5mm²

Color	Signal	7PIN Intercontec plug
1	U	PIN2
2	V	PIN3
3	W	PIN4
Yellow-green	PE	PIN1
Shielded wire	Shield	Internal metal ring

MOTE4-150-LL-S
Wire spec. cable 4C x 1.5mm²

Color	Signal	4PIN Intercontec plug
1	U	PIN2
2	V	PIN3
3	W	PIN4
Yellow-green	PE	PIN1
Shielded wire	Shield	PIN1

MOTE6-180-LL-G
Wire spec. cable 4C x 1.5mm²

Color	Signal	7PIN Intercontec plug
1	U	PIN2
2	V	PIN3
3	W	PIN4
Yellow-green	PE	PIN1
Shielded wire	Shield	PIN1

MOTE6-300-LL-G
Wire spec. cable 4C x 1.5mm²

Color	Signal	4PIN Intercontec plug
1	U	PIN2
2	V	PIN3
3	W	PIN4
Yellow-green	PE	PIN1
Shielded wire	Shield	PIN1

Wiring Diagram for Encoder Cable

ENCE-LL-KL

Wire spec. 1P×24AWG(7/0.20T)+7P×28AWG(7/0.127T)

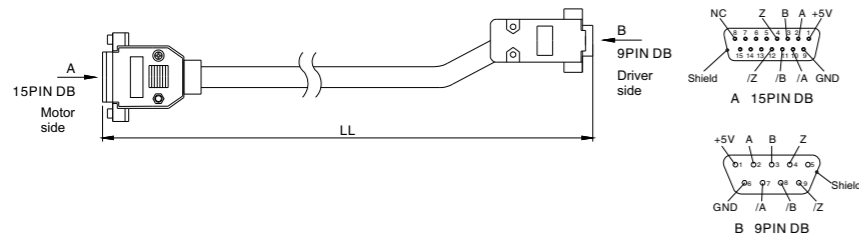

ENCE-LL-KL			
15 PIN DB	Signal	Color	9 PIN DB
PIN1	+5V	Red(thick)	PIN1
PIN2	A	Orange	PIN2
PIN3	B	Yellow	PIN3
PIN4	Z	Green	PIN4
PIN9	GND	Black(thick)	PIN6
PIN10	/A	Orange-white	PIN7
PIN11	/B	Yellow-white	PIN8
PIN12	/Z	Green-white	PIN9
Metal Shell	Shield	Shielded wire	Metal Shell

ENCE-LL-KC1

Wire spec. 1P×24AWG(7/0.20T)+7P×28AWG(7/0.127T)

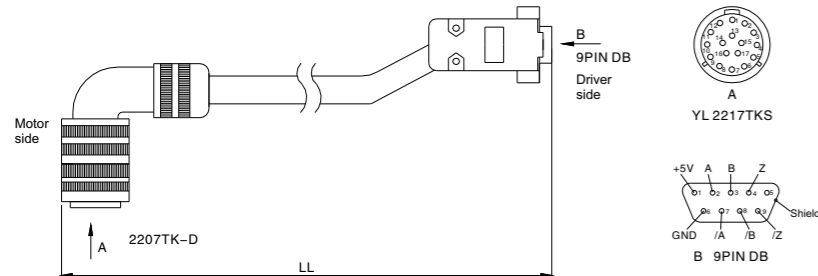

ENCE-LL-KC1			
17 PIN intercontec plug	Signal	Color	9 PIN DB
PIN1	+5V	Red(thick)	PIN1
PIN3	A	Orange	PIN2
PIN5	B	Yellow	PIN3
PIN14	Z	Green	PIN4
PIN2	GND	Black(thick)	PIN6
PIN4	/A	Orange-white	PIN7
PIN6	/B	Yellow-white	PIN8
PIN15	/Z	Green-white	PIN9
Internal metal ring	Shield	Shielded wire	Metal Shell

ENCE4-150-LL-S

Wire spec. 1P×24AWG(7/0.20T)+7P×28AWG(7/0.127T)

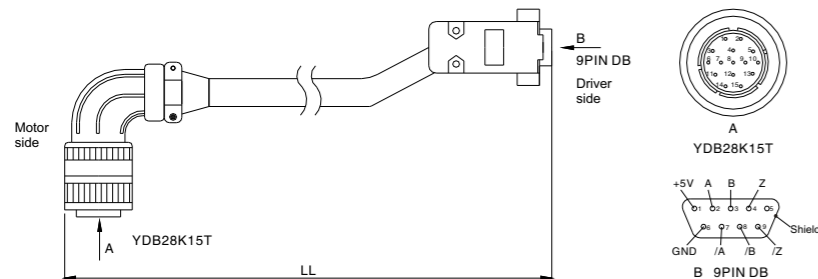

ENCE4-150-LL-S			
15 PIN intercontec plug	Signal	Color	9 PIN DB
PIN2	+5V	Red(thick)	PIN1
PIN4	A	Orange	PIN2
PIN6	B	Yellow	PIN3
PIN8	Z	Green	PIN4
PIN3	GND	Black(thick)	PIN6
PIN5	/A	Orange-white	PIN7
PIN7	/B	Yellow-white	PIN8
PIN9	/Z	Green-white	PIN9
PIN1	Shield	Shielded wire	Metal Shell

ENCE6-180-LL-G

ENCE6-300-LL-G

Wire spec. 1P×24AWG(7/0.20T)+7P×28AWG(7/0.127T)

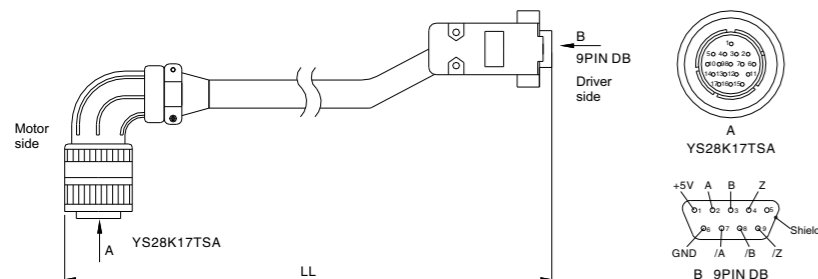

ENCE6-180-LL-G / ENCE6-300-LL-G			
17 PIN intercontec plug	Signal	Color	9 PIN DB
PIN12	+5V	Red(thick)	PIN1
PIN2	A	Orange	PIN2
PIN4	B	Yellow	PIN3
PIN16	Z	Green	PIN4
PIN13	GND	Black(thick)	PIN6
PIN3	/A	Orange-white	PIN7
PIN5	/B	Yellow-white	PIN8
PIN17	/Z	Green-white	PIN9
PIN1	Shield	Shielded wire	Metal Shell

Outline Dimension for 3-phase Servo Driver

Mechanical Dimension Diagram for ED430 Unit:mm

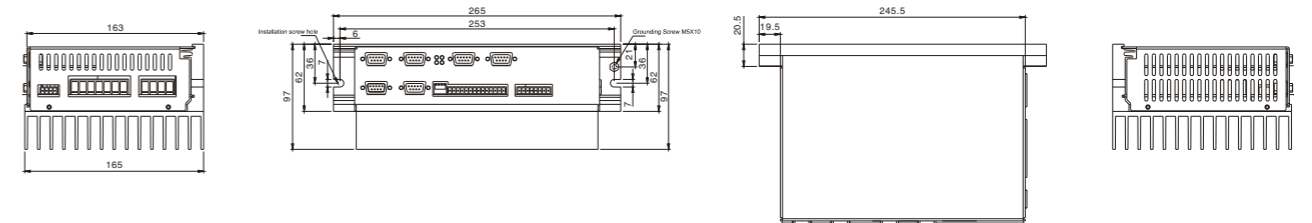

Mechanical Dimension Diagram for ED620 Unit:mm

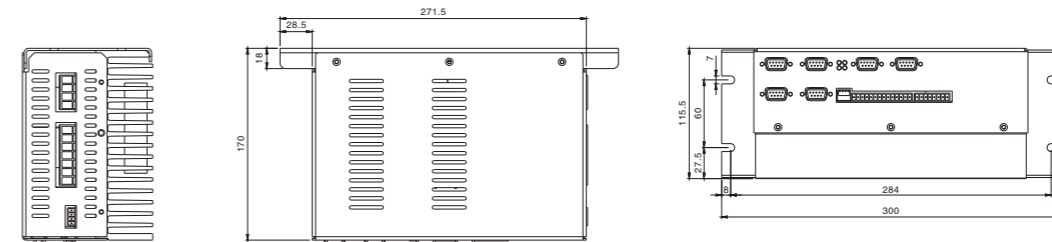

Mechanical Dimension Diagram for ED630 Unit:mm

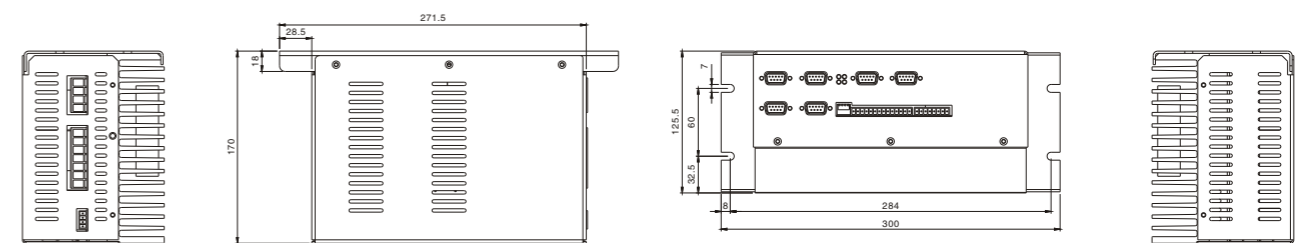

Technical Specifications for 3-phase Servo Drivers

Model parameter	ED430-0020 -XA-K-000	ED430-0040 -XA-K-000	ED430-0075 -XA-K-000	ED430-0100 -XA-K-000	ED430-0105 -XA-S-000	ED430-0105 -XA-K-000	ED430-0125 -XA-K-000	ED430-0126 -XA-K-000	ED430-0157 -XA-S-000
Main supply voltage	Single-phase AC220V ± 15%					3-phase AC220V ± 15%			
Rated power frequency	50Hz ~ 60Hz								
Control circuit voltage	DC24 ± 10% , 2A								
Digital signal input	DC24 ± 10% , 10mA								
Digital signal output	DC24 ± 10% , 0.5A								
Analog signal input	-10V ~ +10V								
Rated output power	0.2	0.4	0.75	1.0	1.05	1.05	1.25	1.26	1.57
Energy-consumed braking	Use an external brake resistor if necessary, ED430 series use minimum resistor of 27Ω								
Energy-consumed braking voltage	DC385 ± 5V								
Over-voltage alarm voltage	DC400 ± 5V								
under-voltage alarm voltage	DC210 ± 5V								
Dimensions (H x W x D)	265 X 165 X 62			265 X 165 X 97					
Weight	1.9Kg			3Kg					
Operation Environment									
Operating temperature	0 ~ 40°C								
Storage temperature	-10 ~ 70°C								
Humidity	5 ~ 85%								
Pollution degree	2								
Protection class	IP20								
Installation environment	Installed in a dust-free, dry, and lockable environment (for example, in a electrical cabinet)								
Installation mode	Vertical installaion								
Installation altitude	No power limit below 1000m								
Air pressure	86 ~ 106kpa								
General Function									
Internal programmable	An internal space of 16.5KB is provided for 256 sequences,which can save a controller on some occasions.								
External digital I/O	3 digital outputs(24V,0.5A),two of which are programmable;the target position to output or alarm output function can be implemented by internal programming. 8 external digital inputs,supporting internal sequences calling via the input interface and positioning function(input delay:about 1ms;input current:about 4mA)								
Analog input	1 differential analog input,implementing control over motor speed and position by analog input;input voltage range 10V,input delay:about 0.1ms								
Analog output	2 analog outputs,capable of monitoring the chage of internal objects								
Comparator	Four internal comparators,with the comparison results to be used to trigger program sequences								
Timer	Implementing delay and trigger program sequences								
Counter	Four groups of internal counters								
Calculator	An internal calculator can be used for data duplication,addition,subtraction,multiplication,division and logic operation								
Internal oscilloscope	The ECO2WIN software enables a user to monitor operation parameters such as speed,position and current on a PC								
Encoder signal output function	In a master/slave control mode,the motor encoder signal output can be the input for the slave signal encoder with a maximum output frequency of 2MHz								
Master encoder input function	Programmable to be pulse/direction signal control,CW/CCW control,electronic gear or electronic cam control(5V signal),with a maximum output frequency of 2MHz								
Feedback signal	Incremental A,B,Z signal								
RS232	9.6K baud rate,supporting a maximum of 127 sites,and supporting direct communication with a PC with the ECO2WIN software,or direct communication with an Kinco touch screen or text								
RS485	Maximum baud rate of 38.4K,supporting a maximum of 127 sites,and communication cables with a length up to 400m								
CAN BUS	Maximum baud rate of 1M,and supporting a maximum of 127 sites								
PROFIBUS DP	Maximum baud rate of 12M,and supporting a maximum of 127 sites								

Model parameter	ED620-0126 -XA-K-000	ED620-0157 -XA-K-000	ED620-0180 -XA-G-000	ED620-0188 -XA-K-000	ED630-0250 -XA-G-000	ED630-0300 -XA-G-000	ED630-0400 -XA-G-000
Main supply voltage	3-phase AC380V ± 15%						
Rated power frequency	50Hz ~ 60Hz						
Control circuit voltage	DC24 ± 10% , 2A						
Digital signal input	DC24 ± 10% , 10mA						
Digital signal output	DC24 ± 10% , 0.5A						
Analog signal input	-10V ~ +10V						
Rated output power	1.26	1.57	1.8	1.88	2.5	3.0	4.0
Energy-consumed braking	Use an external brake resistor if necessary, ED620 series use a minimum resistor of 100Ω , ED630 use a minimum resistor of 68Ω						
Energy-consumed braking voltage	DC670 ± 5V						
Over-voltage alarm voltage	DC710 ± 5V						
under-voltage alarm voltage	DC410 ± 5V						
Dimensions (H x W x D)	300 X 166 X 115.5				300 X 166 X 125.5		
Weight	4.5Kg				4.6Kg		
Operation Environment							
Operating temperature	0 ~ 40°C						
Storage temperature	-10 ~ 70°C						
Humidity	5 ~ 85%						
Pollution degree	2						
Protection class	IP20						
Installation environment	Installed in a dust-free, dry, and lockable environment (for example, in a electrical cabinet)						
Installation mode	Vertical installaion						
Installation altitude	No power limit below 1000m						
Air pressure	86 ~ 106kpa						
General Function							
Internal programmable	An internal space of 16.5KB is provided for 256 sequences,which can save a controller on some occasions.						
External digital I/O	3 digital outputs(24V,0.5A),two of which are programmable;the target position to output or alarm output function can be implemented by internal programming. 8 external digital inputs,supporting internal sequences calling via the input interface and positioning function(input delay:about 1ms;input current:about 4mA)						
Analog input	1 differential analog input,implementing control over motor speed and position by analog input;input voltage range 10V,input delay:about 0.1ms						
Analog output	2 analog outputs,capable of monitoring the chage of internal objects						
Comparator	Four internal comparators,with the comparison results to be used to trigger program sequences						
Timer	Implementing delay and trigger program sequences						
Counter	Four groups of internal counters						
Calculator	An internal calculator can be used for data duplication,addition,subtraction,multiplication,division and logic operation						
Internal oscilloscope	The ECO2WIN software enables a user to monitor operation parameters such as speed,position and current on a PC						
Encoder signal output function	In a master/slave control mode,the motor encoder signal output can be the input for the slave signal encoder with a maximum output frequency of 2MHz						
Master encoder input function	Programmable to be pulse/direction signal control,CW/CCW control,electronic gear or electronic cam control(5V signal),with a maximum output frequency of 2MHz						
Feedback signal	Incremental A,B,Z signal						
RS232	9.6K baud rate,supporting a maximum of 127 sites,and supporting direct communication with a PC with the ECO2WIN software,or direct communication with an Kinco touch screen or text						
RS485	Maximum baud rate of 38.4K,supporting a maximum of 127 sites,and communication cables with a length up to 400m						
CAN BUS	Maximum baud rate of 1M,and supporting a maximum of 127 sites						
PROFIBUS DP	Maximum baud rate of 12M,and supporting a maximum of 127 sites						

Description of Communication Ports and Terminals of ED430 / ED620 / ED630

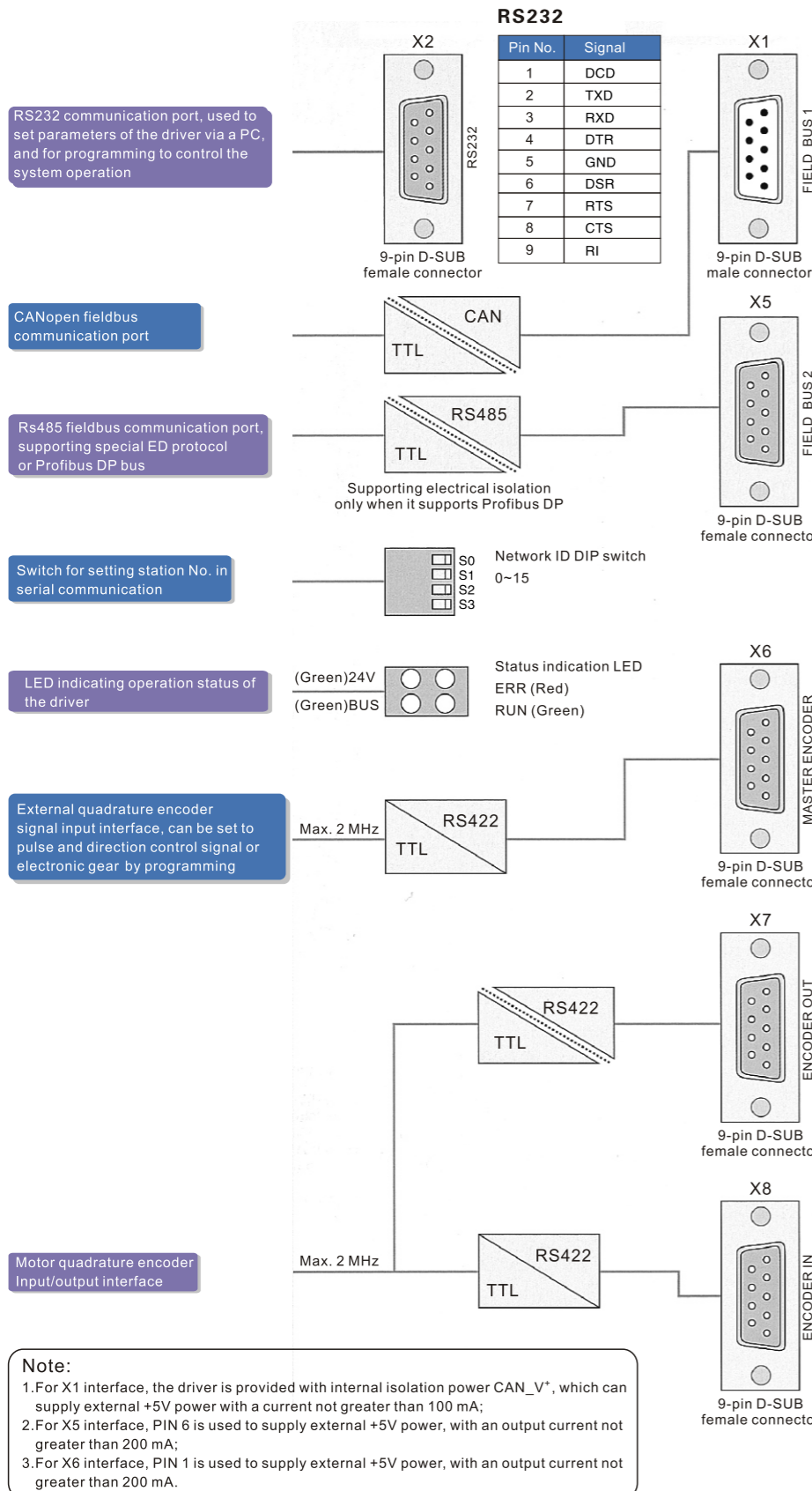

Note:

- For X1 interface, the driver is provided with internal isolation power CAN_V+, which can supply external +5V power with a current not greater than 100 mA;
- For X5 interface, PIN 6 is used to supply external +5V power, with an output current not greater than 200 mA;
- For X6 interface, PIN 1 is used to supply external +5V power, with an output current not greater than 200 mA.

Input/Output Wiring Terminals

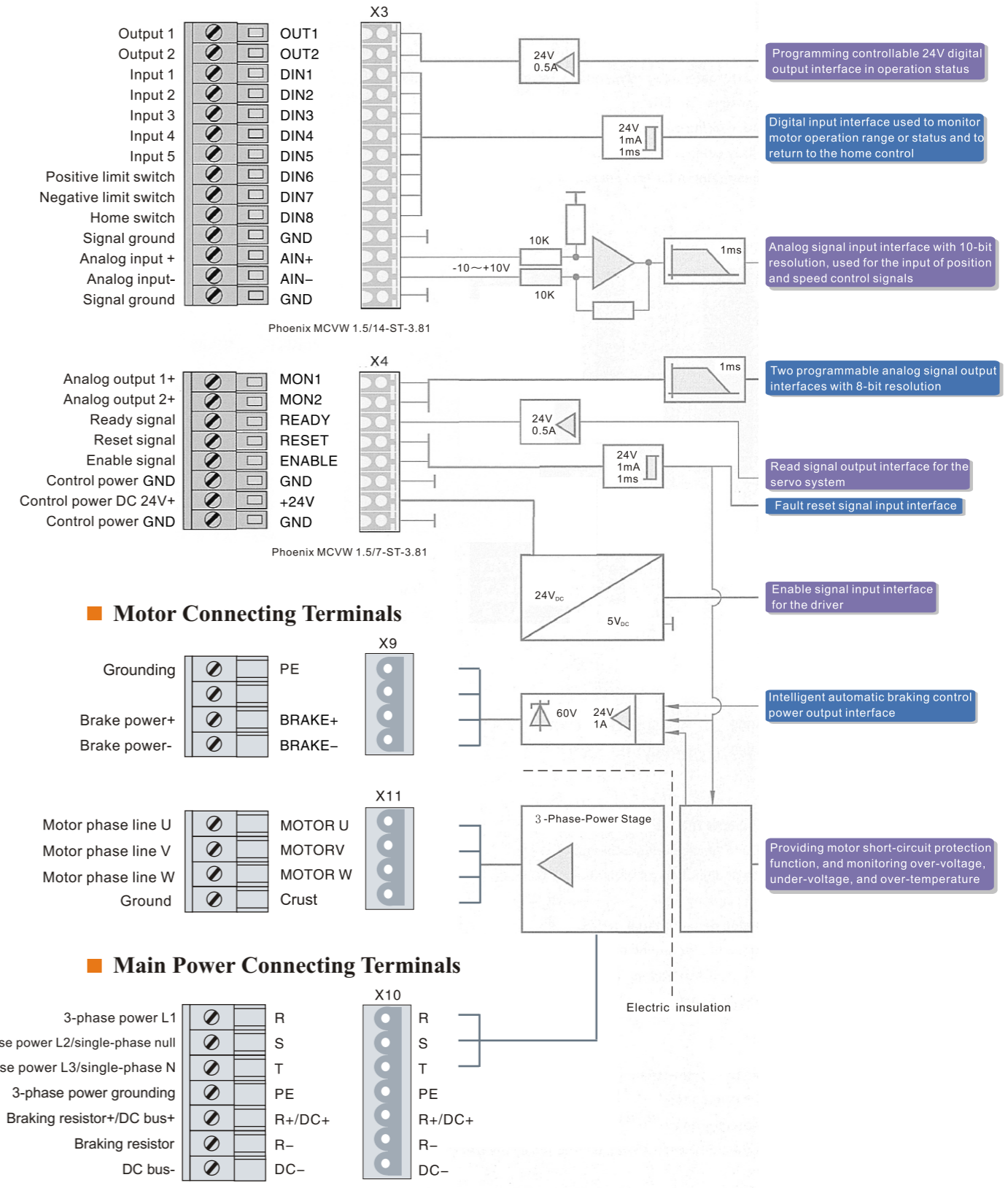

Motor Connecting Terminals

Main Power Connecting Terminals